

EasyPact™

Electrical Auxiliaries and Accessories

Auxiliaires électriques et Accessoires
Auxiliares eléctricos y Accesorios
Auxiliares elétricos e Acessórios

The manufacturer assumes no responsibility for damage resulting from the non-application or incorrect application of the instructions provided herein.

Le non respect des indications de la présente notice ne saurait engager la responsabilité du constructeur.

El fabricante no se responsabiliza de los daños originados como resultado de la falta de aplicación o aplicación incorrecta de las presentes instrucciones.

O fabricante declinará toda e qualquer responsabilidade pelo resultado do não cumprimento das indicações constantes do presente manual de instruções

250A

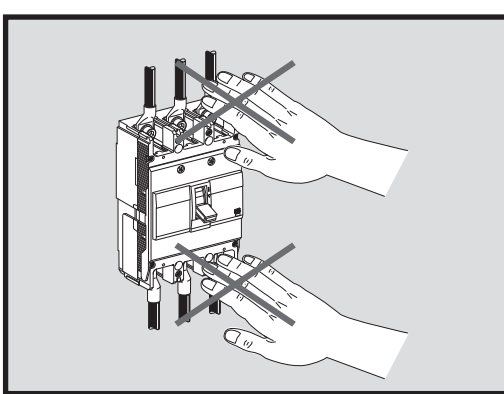
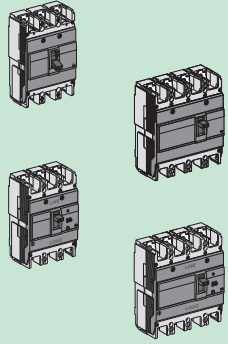

WARNING

Hazardous voltage can shock, burn or cause death. Disconnect power from source before installing, modifying or servicing.

EZETSHD3P - EZETSHD3PN - EZETSHD4PN

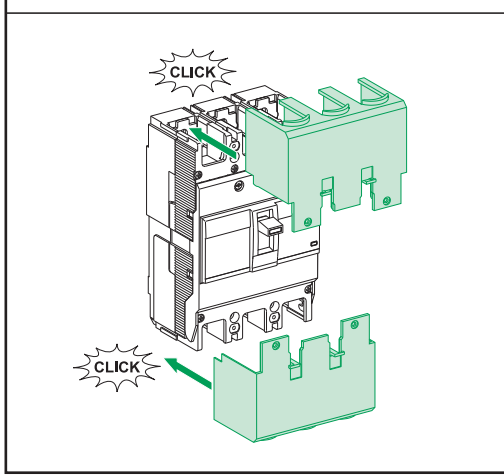

EZEFASB2 - EZEFASB2N - EZEFASB3N

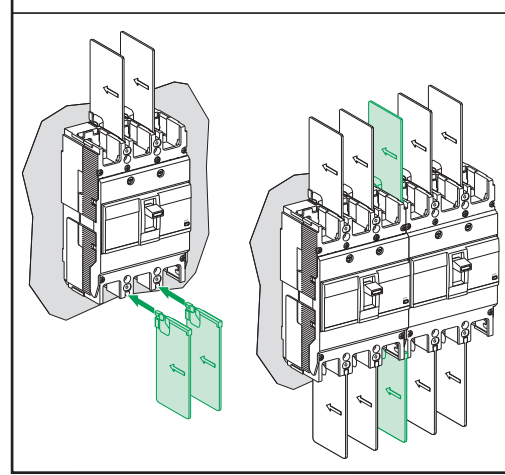

EZELUG2503 - EZELUG2504

kA x 50%
kA x 100%

solid
 ← 42.4 → 152 mm²
 21

8 Nm
15 Nm

EZESPDR3P - EZESPDR4P

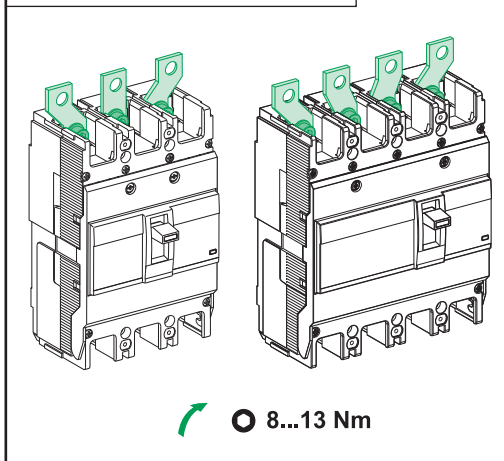

EZESPDR3P - EZESPDR4P

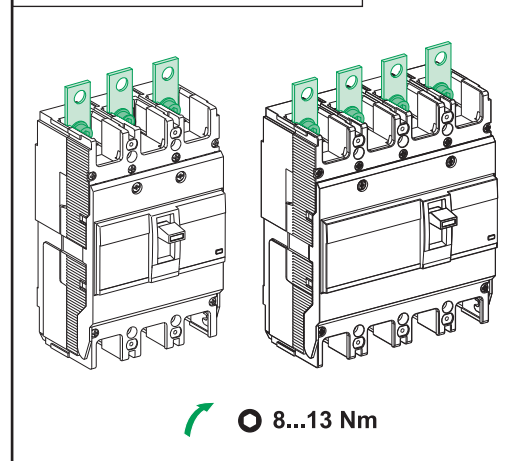

EZELOCK - EZELOCKN

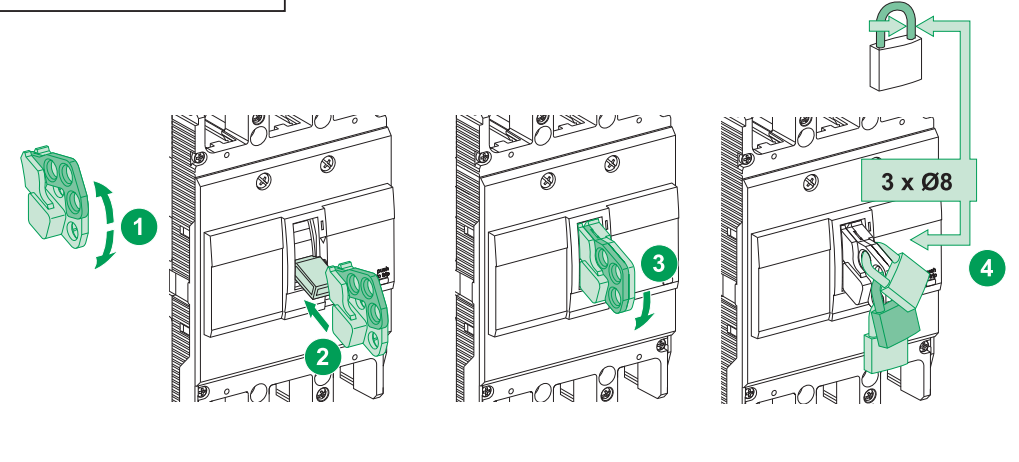

EZEROTDS

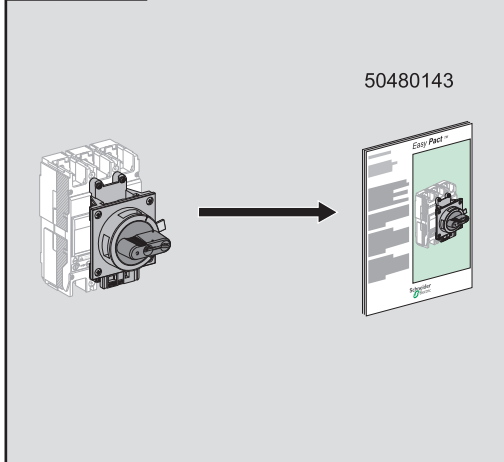

EZEROTE

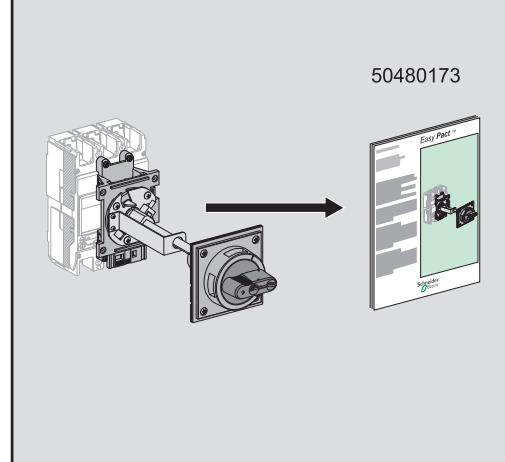

EZEAX, EZEAL, EZEAXAL, EZESHT

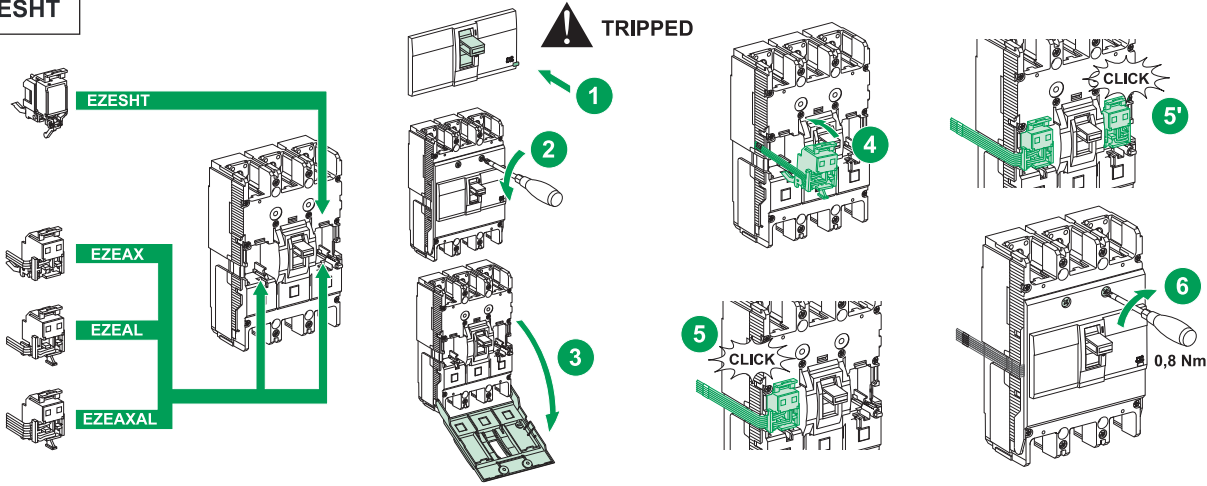
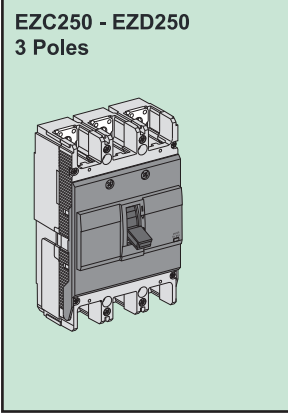

EZEUVR

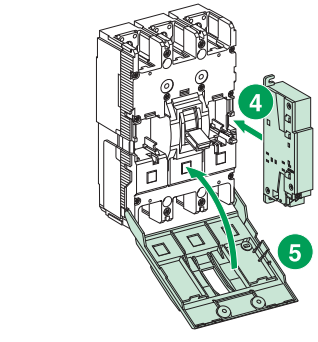

EZEAX, EZEAL, EZEAXAL, EZESHT, EZEUVRN

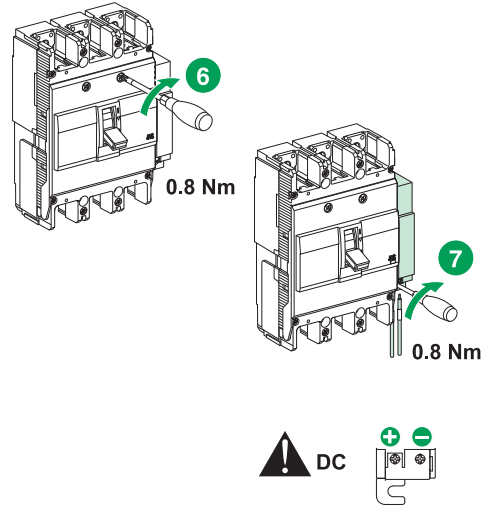
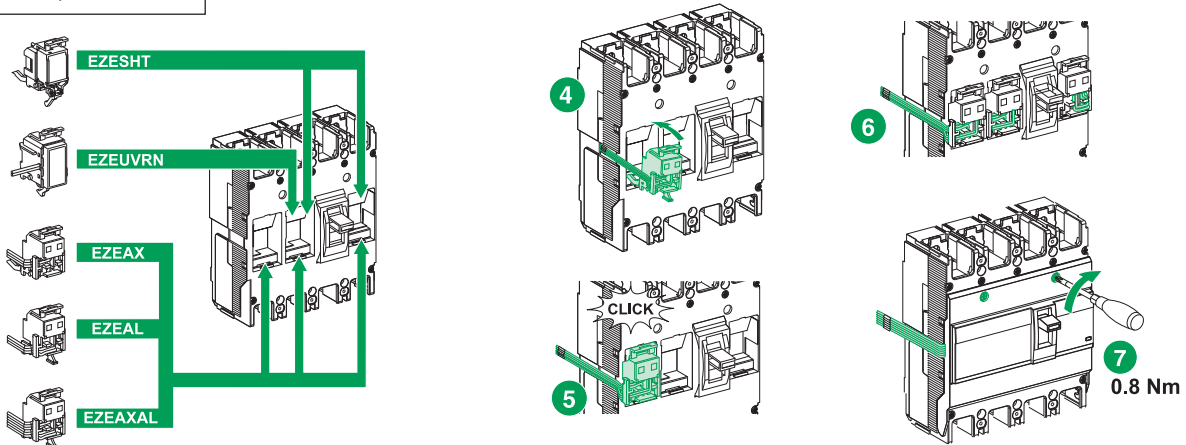
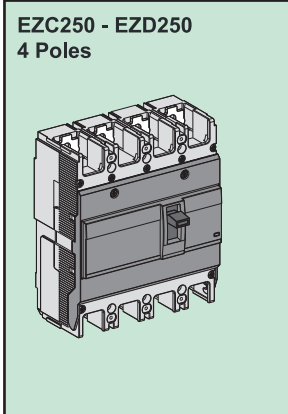

EZEAX, EZEAL, EZEAXAL, EZESHT, EZEUVRN, EZEALV

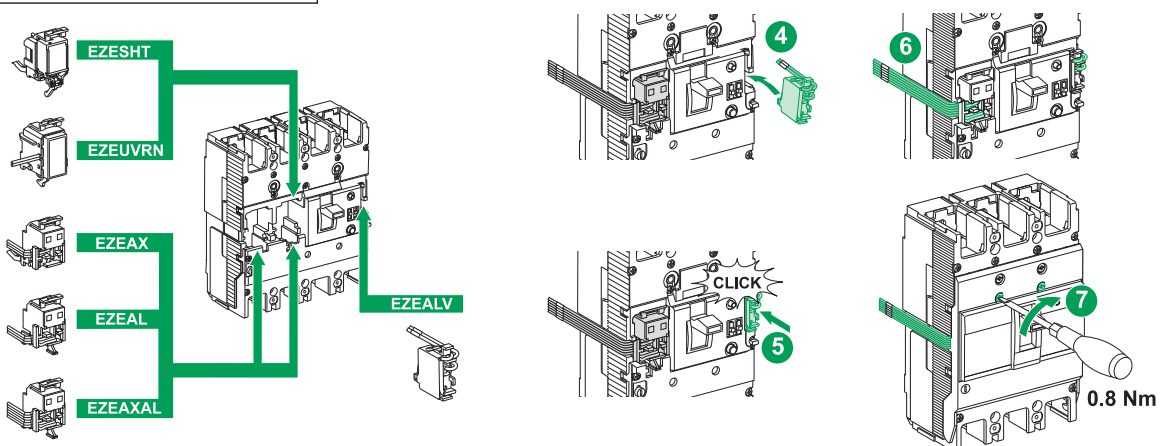
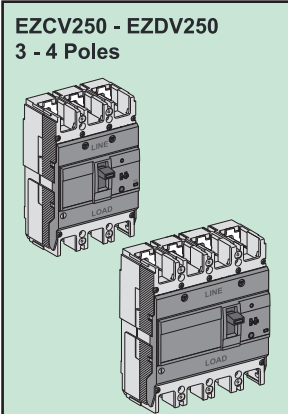

To dismantle

